

cmdStopConvert.Visible = 1

```

Parameters:
BoardNum% :the number used by CB.CFG to describe this board
LowChan%  :first A/D channel of the scan
HighChan% :last A/D channel of the scan
CBCount%  :the total number of A/D samples to collect
CBRate%   :Sample rate in samples per second
Gain%     :the gain of the board
FileName%  :the file name for the collected data values
Options%   :data

```

```

CBCount% = Num
FileName% = r
CBRate% = 5
LowChan% = 0
HighChan% = 1
Options% = 0
Gain% = 1

```

```

DataC
lblAcq
lblShowRate
lblShowLoChan.Caption = Format$(LowChan%, "0")
lblShowHiChan.Caption = Format$(HighChan%, "0")
lblShowOptions.Caption = Format$(Options%, "0")
lblShowGain.Caption = Format$(Gain%, "0")
lblShowFile.Caption = FileName%
lblShowCount.Caption = Format$(CBCount%, "0")
lblShowPreTrig.Caption = "Not Applicable"
Dummy% = DoEvents()

```

```

Collect the values with cbFileAInScan()

```

```

ULStat% = cbFileAInScan(BoardNum%, LowChan%, HighChan%, CBCount%, CBRate%, Gain%, Options%)
If ULStat% = 502 Then
MsgBox "Scan completed successfully. File created with '" & FileName% & "'."

```

```

cmdStopConvert.Enabled = 0
cmdStopConvert.Visible = 0
cmdStartAcq.Enabled = -1
cmdStartAcq.Visible = -1
txtFileName.SetFocus
Exit Sub
ElseIf ULStat% < 500 Then
MsgBox "Scan failed. Error code: " & ULStat%

```

```

Collect the values with cbFileAInScan()

```

```

ULStat% = cbFileAInScan(BoardNum%, LowChan%, HighChan%, CBCount%, CBRate%, Gain%, Options%)
If ULStat% = 502 Then
MsgBox "Enter the name of the file you created with 'MAKESTRM'. File name: " & FileName%
cmdStopConvert.Enabled = 0
cmdStopConvert.Visible = 0
cmdStartAcq.Enabled = -1
cmdStartAcq.Visible = -1
txtFileName.SetFocus
Exit Sub
ElseIf ULStat% < 500 Then
MsgBox "Scan failed. Error code: " & ULStat%

```

```

lblRead
lblReadFile
lblReadTotal.Caption = Format$(TotalCount%, "0")
lblReadPreTrig.Caption = Format$(PreTrigCount%, "0")

```

```

End Sub
Private Sub cmdStopConvert_Click()
End
End Sub

```



# User's Guide

## PMD-1024HLS

USB-based Personal Measurement Device™ brand digital I/O module  
with 24 high-current (15 mA source, 64 mA sink) digital I/O bits

# **PMD-1024HLS**

**Personal Measurement Device™ brand  
USB-based Digital I/O Module**

## **User's Guide**



**MEASUREMENT  
COMPUTING™**

Document Revision 4, May, 2005

© Copyright 2005, Measurement Computing Corporation™

Your new Measurement Computing product comes with a fantastic extra —

## Management committed to your satisfaction!

Refer to [www.mccdaq.com/exceteam.html](http://www.mccdaq.com/exceteam.html) for the names, titles, and contact information of each key executive at Measurement Computing.

Thank you for choosing a Measurement Computing product—and congratulations! You own the finest, and you can now enjoy the protection of the most comprehensive warranties and unmatched phone tech support. It's the embodiment of our two missions:

- To offer the highest-quality, computer-based data acquisition, control, and GPIB hardware and software available—at the best possible price.
- To offer our customers superior post-sale support—FREE. Whether providing unrivaled telephone technical and sales support on our latest product offerings, or continuing that same first-rate support on older products and operating systems, we're committed to you!

**Lifetime warranty:** Every hardware product manufactured by Measurement Computing Corporation is warranted against defects in materials or workmanship for the life of the product. Products found defective are repaired or replaced promptly.

**Lifetime Harsh Environment Warranty®:** We will replace any product manufactured by Measurement Computing Corporation that is damaged (even due to misuse) for only 50% of the current list price. I/O boards face some tough operating conditions—some more severe than the boards are designed to withstand. When a board becomes damaged, just return the unit with an order for its replacement at only 50% of the current list price. We don't need to profit from your misfortune. By the way, we honor this warranty for any manufacturer's board that we have a replacement for.

**30 Day Money Back Guarantee:** You may return any Measurement Computing Corporation product within 30 days of purchase for a full refund of the price paid for the product being returned. If you are not satisfied, or chose the wrong product by mistake, you do not have to keep it. Please call for an RMA number first. No credits or returns accepted without a copy of the original invoice. Some software products are subject to a repackaging fee.

*These warranties are in lieu of all other warranties, expressed or implied, including any implied warranty of merchantability or fitness for a particular application. The remedies provided herein are the buyer's sole and exclusive remedies. Neither Measurement Computing Corporation, nor its employees shall be liable for any direct or indirect, special, incidental or consequential damage arising from the use of its products, even if Measurement Computing Corporation has been notified in advance of the possibility of such damages.*

**Trademark and Copyright Information**

Personal Measurement Device brand, TracerDAQ, Universal Library, *InstaCal*, Harsh Environment Warranty, Measurement Computing Corporation, and the Measurement Computing logo, are either trademarks or registered trademarks of Measurement Computing Corporation.

SoftWIRE is a registered trademark of SoftWIRE Technology, Inc.

Windows, Microsoft, and Visual Studio are either trademarks or registered trademarks of Microsoft Corporation. LabVIEW is a trademark of National Instruments. All other trademarks are the property of their respective owners.

Information furnished by Measurement Computing Corporation is believed to be accurate and reliable. However, no responsibility is assumed by Measurement Computing Corporation neither for its use; nor for any infringements of patents or other rights of third parties, which may result from its use. No license is granted by implication or otherwise under any patent or copyrights of Measurement Computing Corporation.

All rights reserved. No part of this publication may be reproduced, stored in a retrieval system, or transmitted, in any form by any means, electronic, mechanical, by photocopying, recording, or otherwise without the prior written permission of Measurement Computing Corporation.

**Notice**

Measurement Computing Corporation does not authorize any Measurement Computing Corporation product for use in life support systems and/or devices without the written approval of the CEO of Measurement Computing Corporation. Life support devices/systems are devices or systems which, a) are intended for surgical implantation into the body, or b) support or sustain life and whose failure to perform can be reasonably expected to result in injury. Measurement Computing Corporation products are not designed with the components required, and are not subject to the testing required to ensure a level of reliability suitable for the treatment and diagnosis of people.

---

# Table of Contents

<b>About this User's Guide</b> .....	<b>v</b>
What you will learn from this user's guide .....	v
Conventions in this user's guide.....	v
Where to find more information .....	v
<b>Chapter 1</b>	
<b>Introducing the PMD-1024HLS</b> .....	<b>1-1</b>
PMD-1024HLS block diagram .....	1-2
Software features .....	1-2
Connecting a PMD-1024HLS to your computer is easy.....	1-3
<b>Chapter 2</b>	
<b>Installing the PMD-1024HLS</b> .....	<b>2-1</b>
What comes with your PMD-1024HLS shipment? .....	2-1
Hardware .....	2-1
Software.....	2-1
Documentation.....	2-2
Unpacking the PMD-1024HLS .....	2-2
Installing the software.....	2-2
Installing the hardware .....	2-2
<b>Chapter 3</b>	
<b>Functional Details</b> .....	<b>3-1</b>
External components .....	3-1
USB connector.....	3-1
LED .....	3-1
Screw terminal wiring.....	3-2
Main connector and pin out .....	3-2
Digital I/O terminals (Port A0 to A7, Port B0 to B7, Port C0 to C7).....	3-3
Power terminals .....	3-4
Ground terminals .....	3-5
Counter terminal.....	3-5
Pull-up/pull-down terminals .....	3-5
<b>Chapter 4</b>	
<b>Specifications</b> .....	<b>4-1</b>
Digital input/output.....	4-1
Counter section .....	4-2
Power .....	4-2
General.....	4-3
Environmental.....	4-3
Mechanical.....	4-3
Main connector and pin out .....	4-3

## About this User's Guide

### What you will learn from this user's guide

This user's guide explains how to install, configure, and use the PMD-1024HLS so that you get the most out of its USB digital I/O features.

This user's guide also refers you to related documents available on our web site, and to technical support resources that can also help you get the most out of your PMD-1024HLS.

### Conventions in this user's guide

#### For more information on ...

Text presented in a box signifies additional information and helpful hints related to the subject matter you are reading.

**Caution!** Shaded caution statements present information to help you avoid injuring yourself and others, damaging your hardware, or losing your data.

<#:#> Angle brackets that enclose numbers separated by a colon signify a range of numbers, such as those assigned to registers, bit settings, etc.

**bold text** **Bold** text is used for the names of objects on the screen, such as buttons, text boxes, and check boxes. For example:

1. Insert the disk or CD and click the **OK** button.

*italic text* *Italic* text is used for the names of manuals and help topic titles, and to emphasize a word or phrase. For example:

- The *InstaCal*® installation procedure is explained in the *DAQ Software Quick Start*.
- *Never* touch the exposed pins or circuit connections on the board

### Where to find more information

The following electronic documents provide information that can help you get the most out of your Personal Measurement Device™ brand PMD-1024HLS.

- MCC's *Specifications: PMD-1024HLS* (the PDF version of Chapter 4 in this guide) is available on our web site at [www.mccdaq.com/pdfs/PMD-1024HLS.pdf](http://www.mccdaq.com/pdfs/PMD-1024HLS.pdf).
- MCC's *DAQ Software Quick Start* is available on our web site at [www.mccdaq.com/PDFmanuals/DAQ-Software-Quick-Start.pdf](http://www.mccdaq.com/PDFmanuals/DAQ-Software-Quick-Start.pdf).
- MCC's *Guide to Signal Connections* is available on our web site at [www.mccdaq.com/signals/signals.pdf](http://www.mccdaq.com/signals/signals.pdf).
- MCC's *Universal Library User's Guide* is available on our web site at <http://www.mccdaq.com/PDFmanuals/sm-ul-user-guide.pdf>.
- MCC's *Universal Library Function Reference* is available on our web site at <http://www.mccdaq.com/PDFmanuals/sm-ul-functions.pdf>.
- MCC's *Universal Library for LabVIEW™ User's Guide* is available on our web site at [www.mccdaq.com/PDFmanuals/SM-UL-LabVIEW.pdf](http://www.mccdaq.com/PDFmanuals/SM-UL-LabVIEW.pdf).

The *PMD-1024HLS User's Guide* (this document) is available on our web site at [www.mccdaq.com/PDFmanuals/PMD-1024HLS.pdf](http://www.mccdaq.com/PDFmanuals/PMD-1024HLS.pdf).

---

## Introducing the PMD-1024HLS

This user's guide contains all of the information you need to connect the PMD-1024HLS to your computer and to the signals you want to measure. The PMD-1024HLS is part of the Personal Measurement Device brand of USB-based data acquisition products.

The PMD-1024HLS is a USB 2.0 low-speed module supported under Microsoft® Windows® 98 (2<sup>nd</sup> edition), Windows ME, Windows 2000, and Window XP. It is designed for USB 1.1 ports, and was tested for full compatibility with both USB 1.1 and USB 2.0 ports.

Refer to the "Be sure you are using the latest system software" note in Chapter 2, "Installing the PMD-1024HLS," to make sure you are using the latest USB drivers.

The PMD-1024HLS is a high drive, 24-line digital I/O module that includes one 32-bit external event counter. The PMD-1024HLS is powered by the +5 volt USB supply from your computer. No external power is required.

An emulation of the 82C55 in mode 0 (only) sets the direction of the 24 digital I/O lines in four ports. Each digital port can be configured for either input or output. The 74FCT244 outputs are high-drive TTL, capable of sourcing 15 mA and sinking 64 mA.

The PMD-1024HLS is shown in Figure 1-1. All I/O connections are made to the screw terminals on each side of the PMD-1024HLS.



Figure 1-1. PMD-1024HLS



## PMD-1024HLS block diagram

PMD-1024HLS functions are illustrated in the block diagram shown here.

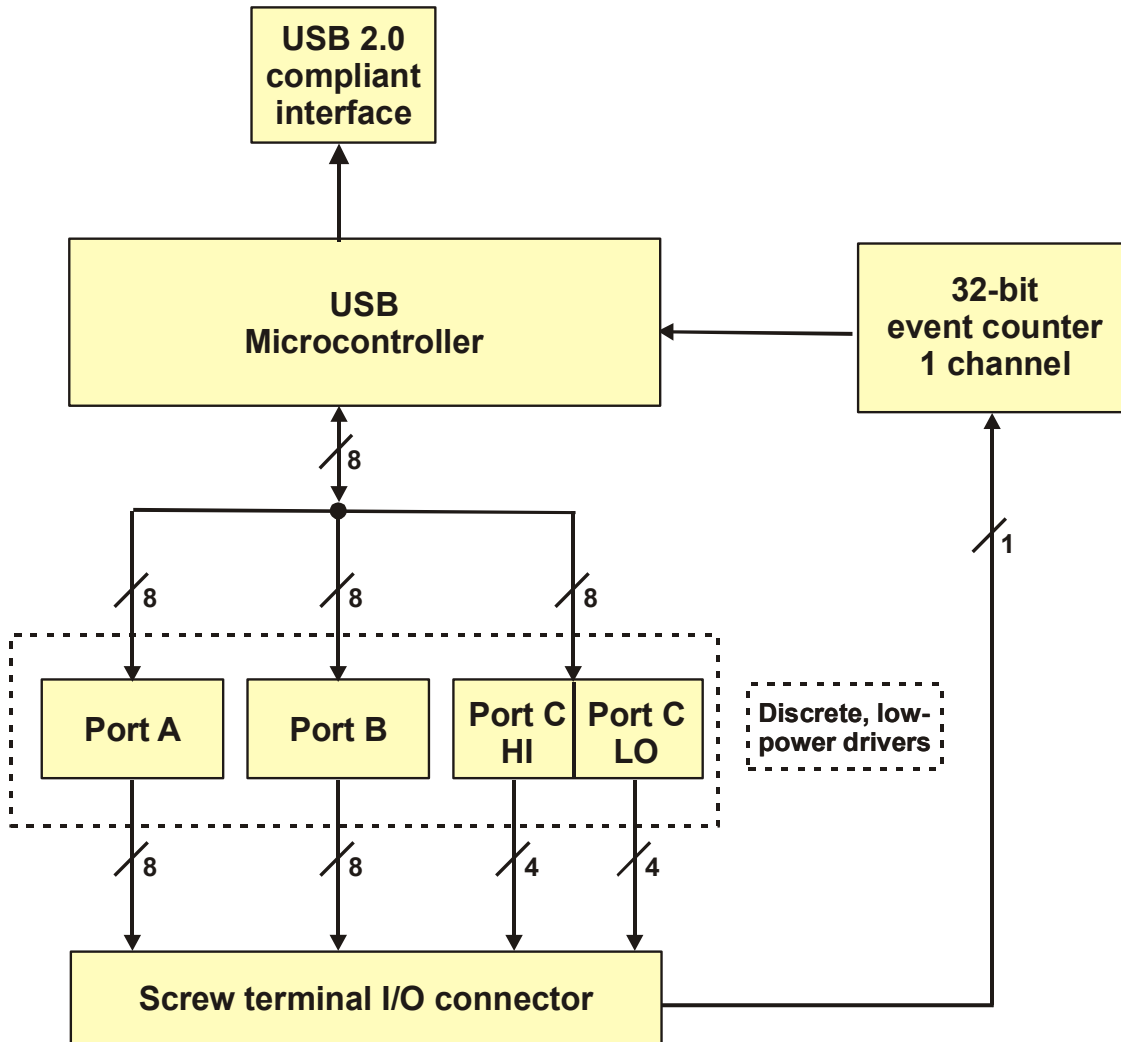

Figure 1-2. PMD-1024HLS functional block diagram

## Software features

The following software ships with the PMD-1024HLS free of charge.

- *InstaCal* installation, calibration, and test utility
- TracerDAQ™ suite of virtual instruments
- SoftWIRE® for Visual Studio® .NET graphical programming
- MCC DAQ Components for VS .NET (installed with SoftWIRE® for VS .NET)

For information on the features of *InstaCal*, TracerDAQ, and SoftWIRE, refer to the *DAQ Software Quick Start* booklet that shipped with the PMD-1024HLS.



## **Connecting a PMD-1024HLS to your computer is easy**

Installing a data acquisition device has never been easier.

- The PMD-1024HLS relies upon the Microsoft Human Interface Device (HID) class drivers. The HID class drivers ship with every copy of Windows that is designed to work with USB ports. We use the Microsoft HID because it is a standard, and its performance delivers full control and maximizes data transfer rates for your PMD-1024HLS. No third-party device driver is required.
- The PMD-1024HLS is plug-and-play. There are no jumpers to position, DIP switches to set, or interrupts to configure.
- You can connect the PMD-1024HLS before or after you install the software, and without powering down your computer first. When you connect an HID to your system, your computer automatically detects it and configures the necessary software. You can connect and power multiple HID peripherals to your system using a USB hub.
- You can connect your system to various devices using a standard four-wire cable. The USB connector replaces the serial and parallel port connectors with one standardized plug and port combination.
- You do not need a separate power supply module. The USB automatically delivers the electrical power required by each peripheral connected to your system.
- Data can flow two ways between a computer and peripheral over USB connections.

---

# Installing the PMD-1024HLS

## What comes with your PMD-1024HLS shipment?

As you unpack your PMD-1024HLS, make sure that the following components are included.

### Hardware

- PMD-1024HLS



- USB cable (2 meter length)



### Software

The *Measurement Computing Data Acquisition Software* CD contains the following software:

- *InstaCal* installation, calibration, and test utility
- TracerDAQ suite of virtual instruments
- SoftWIRE for VS .NET
- SoftWIRE MCC DAQ Components for .NET



## Documentation

In addition to this hardware user's guide, you should also receive the *DAQ Software Quick Start* (available in PDF at [www.mccdaq.com/PDFmanuals/DAQ-Software-Quick-Start.pdf](http://www.mccdaq.com/PDFmanuals/DAQ-Software-Quick-Start.pdf)). Read this booklet completely before installing any software and hardware.



## Unpacking the PMD-1024HLS

As with any electronic device, you should take care while handling to avoid damage from static electricity. Before removing the PMD-1024HLS from its packaging, ground yourself using a wrist strap or by simply touching the computer chassis or other grounded object to eliminate any stored static charge.

If any components are missing or damaged, notify Measurement Computing Corporation immediately by phone, fax, or e-mail. For international customers, contact your local distributor where you purchased the PMD-1024LS.

- Phone: 508-946-5100 and follow the instructions for reaching Tech Support.
- Fax: 508-946-9500 to the attention of Tech Support
- Email: [techsupport@measurementcomputing.com](mailto:techsupport@measurementcomputing.com)

## Installing the software

Refer to the *DAQ Software Quick Start* for instructions on installing the software on the *Measurement Computing Data Acquisition Software CD*. This booklet is available in PDF at [www.mccdaq.com/PDFmanuals/DAQ-Software-Quick-Start.pdf](http://www.mccdaq.com/PDFmanuals/DAQ-Software-Quick-Start.pdf).

## Installing the hardware

### Be sure you are using the latest system software

Before you connect the PMD-1024HLS, make sure that you are using the latest versions of the USB drivers.

Before installing the PMD-1024HLS, download and install the latest Microsoft Windows updates. In particular, when using Windows XP, make sure you have XP Hotfix KB822603 installed. This update is intended to address a serious error in Usbport.sys when you operate a USB device. You can run Windows Update or download the update from [www.microsoft.com/downloads/details.aspx?familyid=733dd867-56a0-4956-b7fe-e85b688b7f86&displaylang=en](http://www.microsoft.com/downloads/details.aspx?familyid=733dd867-56a0-4956-b7fe-e85b688b7f86&displaylang=en). For more information, refer to the Microsoft Knowledge Base article "*Availability of the Windows XP SP1 USB 1.1 and 2.0 update.*" This article is available at [support.microsoft.com/?kbid=822603](http://support.microsoft.com/?kbid=822603).

To connect the PMD-1024HLS to your system, turn your computer on, and connect the USB cable to a USB port on your computer or to an external USB hub that is connected to your computer. The USB cable provides power and communication to the PMD-1024HLS.

When you connect the PMD-1024HLS for the first time, a **Found New Hardware** popup balloon (Windows XP) or dialog (other Windows versions) appear as the PMD-1024HLS is detected.

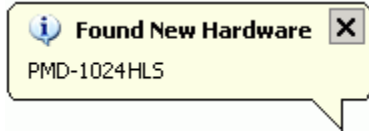

Another **Found New Hardware** balloon or dialog opens that identifies the PMD-1024HLS as a USB Human Interface Device.

When the balloon or dialog closes, the LED on the PMD-1024HLS should flash and then remain lit. This indicates that communication is established between the PMD-1024HLS and your computer

**Caution!** Do not disconnect **any** device from the USB bus while the computer is communicating with the PMD-1024HLS, or you may lose data and/or your ability to communicate with the PMD-1024HLS.

**If the LED turns off**

If the LED is lit but then turns off, the computer has lost communication with the PMD-1024HLS. To restore communication, disconnect the USB cable from the computer, and then reconnect it. This should restore communication, and the LED should turn back *on*.

## Functional Details

### External components

The PMD-1024HLS has the following external components, as shown in Figure 3-1.

- USB connector
- LED
- Screw terminal banks (2)

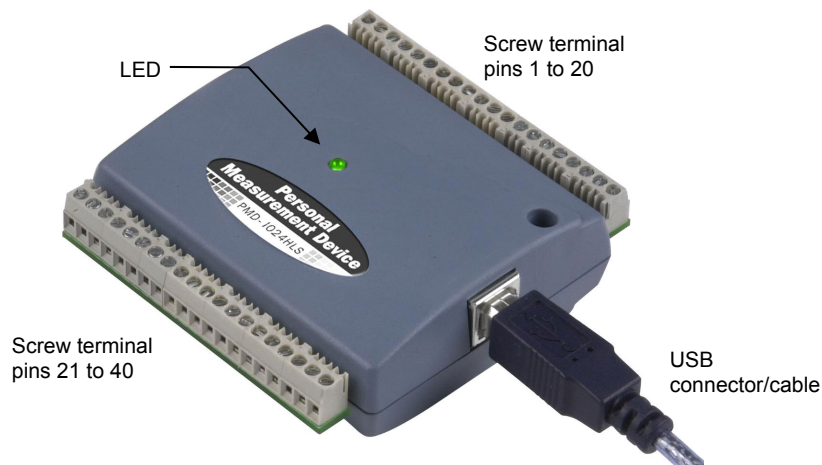

Figure 3-1. PMD-1024HLS external components

### USB connector

The USB connector is on the right side of the PMD-1024HLS housing. This connector provides +5 V power and communication. The voltage output is system-dependent, and may be less than +5 V. No external power supply is required.

### LED

The LED on the front of the housing indicates the communication status of the PMD-1024HLS. It uses up to 5 mA of current and cannot be disabled. Table 3-1 explains the function of the PMD-1024HLS LED.

Table 3-1 LED illumination

LED Illumination	Indication
Steady green	The PMD-1024HLS is connected to a computer or external USB hub.
Blinks continuously	Data is being transferred.
Blinks three times	Initial communication is established between the PMD-1024HLS and the computer.

## Screw terminal wiring

The PMD-1024HLS has two rows of screw terminals—one row on the top edge of the housing, and one row on the bottom edge. Each row has 20 connections. Pin numbers are identified here.



Figure 3-2. PMD-1024HLS screw terminal pin numbers

### Screw terminal – pins 1-20

The screw terminals on the top edge of the PMD-1024HLS (pins 1 to 20) provide the following connections:

- Eight digital I/O connections (**Port C0 to Port C7**)
- One counter connection (**CTR**)
- Two power connections (**USB +5 V**)
- Three pull-up and pull-down connections (**Port A Pull-up/Pull-down, Port B Pull-up/Pull-down and Port C Pull-up/Pull-down**)
- Six ground connections (**GND**)

### Screw terminal – pins 21-40

The screw terminals on the bottom edge of the PMD-1024HLS (pins 21 to 40) provide the following connections:

- 16 digital I/O connections (**Port A0 to Port A7, and Port B0 to Port B7**)
- One power connection (**USB +5 V**)
- Three ground connections (**GND**)

### Main connector and pin out

Connector type	Screw terminal
Wire gauge range	16 AWG to 30 AWG

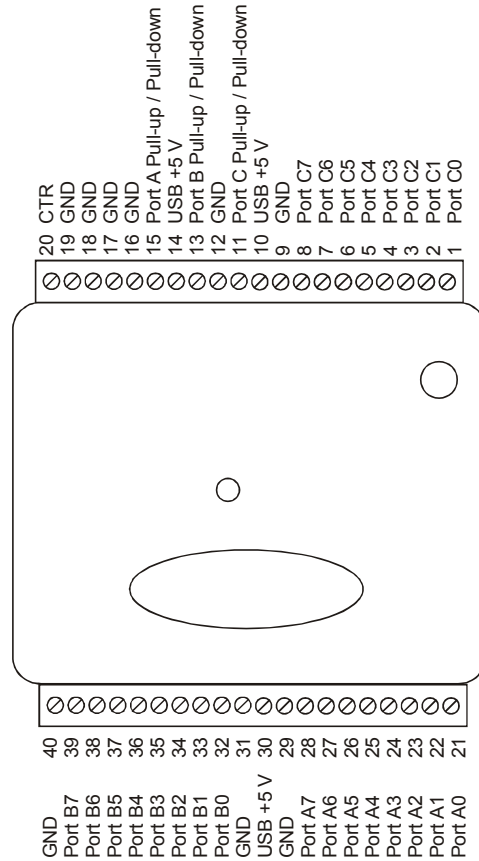

### Digital I/O terminals (Port A0 to A7, Port B0 to B7, Port C0 to C7)

Connect up to 24 digital I/O lines to the screw terminal containing pins 1 to 8 (**Port C0 to Port C7**), pins 21 to 28 (**Port A0 to Port A7**), and pins 32 to 39, (**Port B0 to Port B7**). Refer to the pinout diagram on page 3-2 for the location of these pins. You can configure each digital port for either input or output.

When configured for input, you can use the PMD-1024HLS digital I/O terminals to detect the state of any TTL level input. Refer to the switch shown in Figure 3-3 and the schematic shown in Figure 3-4. If you set the switch to the +5 V input, Port A0 reads TRUE (1). If you move the switch to GND, Port A0 reads FALSE.

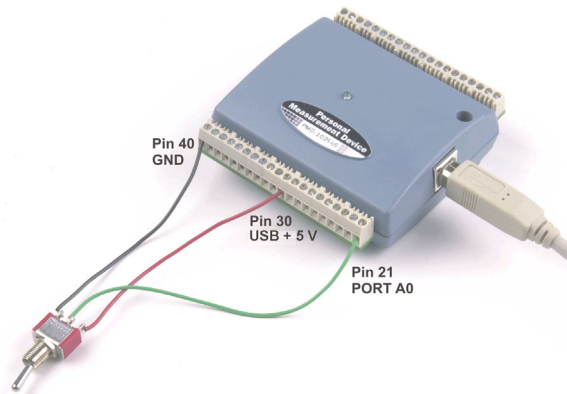

Figure 3-3. Digital connection of Port A0 detecting the state of a switch



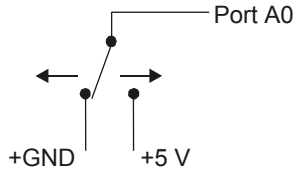

Figure 3-4. Schematic showing switch detection by digital channel Port A0

#### For more information on digital signal connections

For more information on digital signal connections and digital I/O techniques, refer to the *Guide to Signal Connections* (available on our web site at [www.mccdaq.com/signals/signals.pdf](http://www.mccdaq.com/signals/signals.pdf)).

### Power terminals

The USB +5 V connection (pin 30) is on the bottom screw terminal of the PMD-1024HLS. Refer to the pinout diagram on page 3-2 for the location of this terminal. This terminal draws power from the USB connector. The +5 volt screw terminal is a +5 volt output that is supplied by the connected computer.

**Caution!** The USB +5 V terminal is an output. Do not connect to an external power supply or you may damage the PMD-1024HLS and possibly the computer.

Just connecting the PMD-1024HLS to your computer draws 60 mA of current from the USB +5 V supply. Once you start running applications with the PMD-1024HLS, each DIO bit can draw up to 15 mA. The maximum amount of +5 V current available for external use, over and above that required by the PMD-1024HLS, is the difference between the total current requirement of the PMD-1024HLS (based on the application), and the allowed current draw of the computer platform.

The following power limits depend on whether you are sourcing current out of the PMD-1024HLS, or you are sinking current into the PMD-1024HLS.

#### Output (source) current limits: desktop computers and self-powered hubs

The maximum allowed current draw for a typical desktop computer and self-powered hub is 500 mA. For an application running on a PC or self-powered hub, this value yields a maximum user current of  $500 \text{ mA} - 60 \text{ mA} = 440 \text{ mA}$ . Since each DIO line can output 15 mA maximum,  $24 \text{ DIO} \times 15 \text{ mA} = 360 \text{ mA}$  (maximum rating for the chips).

#### Output (source) current limits: notebook computers and bus-powered hubs

The maximum allowed current draw for a typical notebook computer and bus-powered hub is 100 mA.

Because the PMD-1024HLS needs 60 mA from the USB +5 V supply, this leaves you with only 40 mA. If you want to use 15 mA per DIO line, you can only do so with two DIO lines. To overcome this limitation, an external self-powered hub can be used to supply the proper current level required for full output capability as noted above.

#### Output (sink) current limits

Each PMD-1024HLS DIO output can sink up to 64 mA. For an individual line, this is not a problem. But if you were to apply this maximum load to all 24 DIO lines, you would damage the PMD-1024HLS because the total amount of current is well over the 440 mA maximum ( $24 \text{ DIO} \times 64 \text{ mA} = 1536 \text{ mA} \approx 1.54 \text{ A}$ ).

If you want to sink the maximum of 64 mA per DIO line, you can only do so with up to six lines ( $440 \text{ mA} \div 64 \text{ mA/line} = 6.8 \approx 6$  lines). To sink current with all 24 DIO outputs at any one time, you can sink a maximum of 18 mA per line.

## Ground terminals

The nine ground (**GND**) connections are identical, and provide a common ground for all PMD-1024HLS functions. Refer to the pinout diagram on page 3-2 for the location of the **GND** terminal.

## Counter terminal

Pin 20 (**CTR**) is the input to the 32-bit external event counter. Refer to the pinout diagram on page 3-2 for the location of this terminal. The internal counter increments when the TTL levels transition from low to high. The counter can count frequencies of up to 1 MHz.

## Pull-up/pull-down terminals

You can wire pin 11 (**Port C Pull-up/Pull-down**), pin 13 (**Port B Pull-up/Pull-down**), and pin 15 (**Port A Pull-up/Pull-down**) to support a pull-up or pull-down connection. These terminals configure the internal 47K resistors on the PMD-1024HLS.

Refer to the pinout diagram on page 3-2 for the location of these terminals. These terminals are configured as open by default.

- To configure a pull-up connection for a specific port, wire the pull-up/pull-down terminal to a **USB +5 V** terminal.

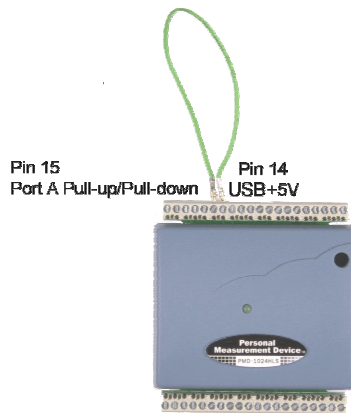

Figure 3-5. Pull-up connection for Port A

- To configure a pull-down connection for a specific port, wire the pull-up/pull-down terminal to a **GND** terminal.

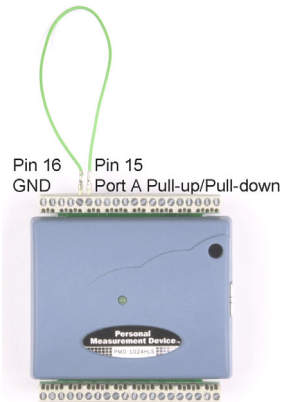

Figure 3-6. Pull-down connection for Port A

Wiring schematics are shown here for each pull-up/pull-down terminal. Dotted lines represent a pull-up or pull-down connection.

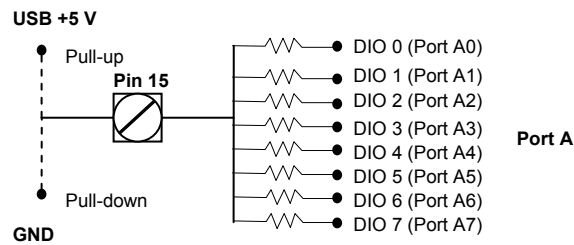

Figure 3-7. Schematic showing Port A pull-up/pull-down wiring options

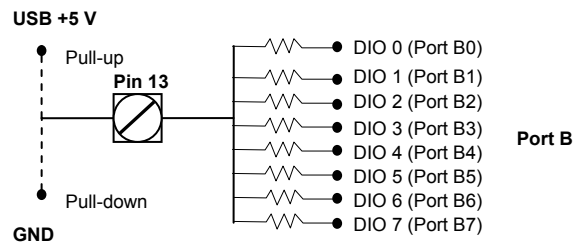

Figure 3-8. Schematic showing Port B pull-up/pull-down wiring options

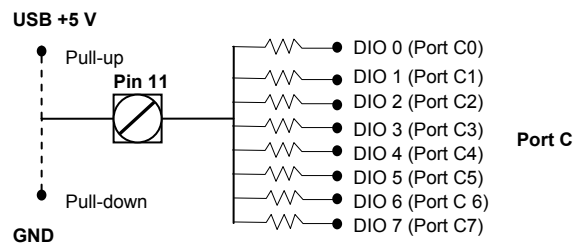

Figure 3-9. Schematic showing Port C pull-up/pull-down wiring options

## Specifications

Typical for 25 °C unless otherwise specified. Specifications in *italic text* are guaranteed by design.

### Digital input/output

Table 4-1. Digital I/O specifications

Digital input type	74ACT373
Digital output type	74FCT244
Number of I/O	24 (port A0 through port C7)
Configuration	2 banks of 8 and 2 banks of 4 or 3 banks of 8
Pull up/pull-down configuration	Internal 47K resistors may be user configured for pull-up or pull-down via external connection of "Port x Pull-up / Pull-down" to "USB +5 V" or "GND". Ports A, B, and C are independently configurable.
Input high voltage	2.0 V min, 5.5 V absolute max
Input low voltage	0.8 V max, -0.5 V absolute min
Output high voltage (IOH = -15 mA)	2.4 V min
Output low voltage (IOL=64 mA)	0.55 V max
Source current – (Note 1) ▪ Self -powered hub ▪ Externally-powered root port hub	Maximum = 15 mA per output
Source current – (Note 2) ▪ Bus-powered hub ▪ Battery-powered root port hub.	Per pin maximum = 40 mA/ [number of active outputs]. 15 mA max source current for any single output
Sink current - (Note 3)	Current sink max: 440 mA/ [number of outputs]. 64 mA max sink current for any single output.
Power up/reset state	Input mode (high impedance)

**Note 1:** "Self-powered hub" refers to a USB hub with an external power supply. Self-powered hubs allow a connected USB device to draw up to 500 mA. "Root port hubs" reside in the PC's USB Host Controller. The USB port(s) on your PC are root port hubs. All externally powered root port hubs (i.e. desktop PC's) provide up to 500 mA of current for a USB device. In this configuration, all 24 digital outputs of the PMD-1024HLS can source their per-pin maximum of 15 mA. This provides a total requirement of 15 mA\*24 = 360 mA. Combining this with the PMD-1024HLS operating current of 60 mA a fully-loaded current draw of 420 mA is realized.

**Note 2:** "Bus-powered hub" refers to a USB hub that derives power directly from the USB +5 V and does not have its own power supply. These hubs allow a connected USB device to draw up to 100 mA. Battery-powered root port hubs provide 100 mA or 500 mA, depending upon the manufacturer. A laptop PC that is not connected to an external power adapter is an example of a battery-powered root port hub. If your laptop is constrained to the 100 mA maximum you have two options when using a PMD-1024HLS. In order to take advantage of the full drive capability of 15 mA per pin you will need to purchase a self-powered hub. Otherwise the total output drive must be de-rated. When de-rated, the total available source current for the digital outputs is the difference between the unloaded operating current of the PMD-1024HLS (60 mA) and the 100 mA overall maximum.

**Note 3:** A low-side resettable fuse protects the PMD-1024HLS. This is designed to protect the host PC or hub from an over current condition. Assuming all return currents in sinking applications return via the USB cable ground signal, the maximum allowable return current is 500 mA. Please include the PMD-1024HLS unloaded operating current (60 mA) in your power budget.

## Counter section

Table 4-2. Counter specifications

Pin name (Note 4)	CTR
Counter type	Event counter
Number of channels	1
Input source	CTR screw terminal
Resolution	32 bits
Schmidt trigger hysteresis	20 mV to 100 mV
Input leakage current	$\pm 1 \mu A$
Maximum input frequency	1 MHz
High pulse width	500 ns min
Low pulse width	500 ns min
Input low voltage	0 V min, 1.0 V max
Input high voltage	4.0 V min, 15.0 V max

**Note 4:** CTR is a Schmitt trigger input

## Power

Table 4-3. Power specifications

Parameter	Conditions	Specification
Supply current (Note 5)	No Load	60 mA
Input power requirements (Note 6)		4.75 V min, 5.25 V max
USB +5 V power available	Measured at "USB +5 V" screw terminals (pins 10,14 and 30)	4.4 V min, 5.25 V max
USB +5 V power output current (Note 7)	Connected to: <ul style="list-style-type: none"> <li>▪ Self-powered hub</li> <li>▪ Externally-powered root port hub</li> </ul>	[350 mA] – [total output source current]
	Connected to <ul style="list-style-type: none"> <li>▪ Bus-powered hub</li> <li>▪ Battery-powered root port hub.</li> </ul>	[60 mA] – [total output source current]
USB +5 V overcurrent protection	Resettable fuse	Hold current: 350 mA, typical
		Trip current: 700 mA typical
		Trip/recovery time: 100 mS, max
		On resistance: 1.3 Ohms max

**Note 5:** This is the total (no load) current requirement for the PMD-1024HLS.

**Note 6:** Bus-powered hubs are allowed to provide downstream USB power as low as 4.4 V. Although your PMD-1024HLS will typically function at this 4.4 V minimum, guaranteed performance requires a minimum power supply voltage of 4.75 V. All self-powered and root port hubs will meet this 4.75 V minimum.

**Note 7:** See available source/sink current level in the "Digital input/output" section.

## General

Table 4-4. General specifications

Parameter	Conditions	Specification
USB controller clock error	25 °C	±30 ppm max
	0 to 70 °C	±50 ppm max
Device type		USB 1.1 low-speed
Device compatibility		USB 1.1, USB 2.0

## Environmental

Table 4-5. Environmental specifications

Operating temperature range	0 to 70 °C
Storage temperature range	-40 to 85 °C
Humidity	0 to 90% non-condensing

## Mechanical

Table 4-6. Mechanical specifications

Dimensions	79 mm (L) x 82 mm (W) x 25 mm (H)
USB cable Length	2 meters max
USB cable type	A-B cable, UL type AWM 2527 or equivalent. (min 24 AWG VBUS/GND, min 28 AWG D+/D-)
User connection length	3 meters max

## Main connector and pin out

Table 4-7. Connector specifications

Connector type	Screw terminal
Wire gauge range	30-16 AWG

Table 4-8. Connector pin out

Pin	Signal Name	Pin	Signal Name
1	Port C0	21	Port A0
2	Port C1	22	Port A1
3	Port C2	23	Port A2
4	Port C3	24	Port A3
5	Port C4	25	Port A4
6	Port C5	26	Port A5
7	Port C6	27	Port A6
8	Port C7	28	Port A7
9	GND	29	GND
10	USB +5 V	30	USB +5 V
11	Port C Pull-up / Pull-down	31	GND
12	GND	32	Port B0
13	Port B Pull-up / Pull-down	33	Port B1
14	USB +5 V	34	Port B2
15	Port A Pull-up / Pull-down	35	Port B3
16	GND	36	Port B4
17	GND	37	Port B5
18	GND	38	Port B6
19	GND	39	Port B7
20	CTR	40	GND

# CE Declaration of Conformity

Manufacturer: Measurement Computing Corporation  
Address: 16 Commerce Boulevard  
Middleboro, MA 02346  
USA

Category: Electrical equipment for measurement, control and laboratory use.

Measurement Computing Corporation declares under sole responsibility that the product  
PMD-1024HLS

to which this declaration relates is in conformity with the relevant provisions of the following standards or other documents:

**EU EMC Directive 89/336/EEC: Electromagnetic Compatibility, EN 61326 (1997) Amendment 1 (1998)**

Emissions: Group 1, Class A

- EN 55011 (1998)/CISPR 11: Radiated and Conducted emissions.

Immunity: EN61326, Annex A

- EN 61000-4-2 (1995): Electrostatic Discharge immunity, Criteria C.
- EN 61000-4-3 (1997): Radiated Electromagnetic Field immunity Criteria A.
- EN 61000-4-8 (1995): Power Frequency Magnetic Field immunity Criteria A.

Power line and I/O tests to EN61000-4-4, EN61000-4-5, EN61000-4-6, and EN61000-4-11 were not required. The device is DC powered from an I/O cable which is less than three meters long.

Declaration of Conformity based on tests conducted by Chomerics Test Services, Woburn, MA 01801, USA in June, 2004. Test records are outlined in Chomerics Test Report #EMI3902.04.

We hereby declare that the equipment specified conforms to the above Directives and Standards.



Carl Haapaoja, Vice-President of Design Verification



**Measurement Computing Corporation**  
**16 Commerce Boulevard,**  
**Middleboro, Massachusetts 02346**  
**(508) 946-5100**  
**Fax: (508) 946-9500**  
**E-mail: [info@mccdaq.com](mailto:info@mccdaq.com)**  
**[www.mccdaq.com](http://www.mccdaq.com)**